

Miller[®]matic 210

Issued January 2003 • Index No. DC/12.46

**MIG Arc Welding
Power Source** 

Quick Specs

Industrial Applications

Light Fabrication
Garages/Body Shops
Vocational/Technical Schools
Farm/Ranch

Processes

MIG (GMAW)
Flux Cored (FCAW)

Rated Output 160 A at 24.5 VDC, 60% Duty Cycle

Max. Open-Circuit Voltage 34.5

Amperage Range 30 – 210 A

Wire Feed Speed 35 – 700 IPM (0.9 – 17.8 m/min)

Weight 200 lb (91 kg)

The Power of Blue.[®]



Removable consumable compartment and access to wire drive system located under side door.



Add the Spoolmate™ 3035 spool gun for aluminum welding. Easy to install with new, direct hook up. And with Miller's exclusive Gun-On-Demand™, simply pull the trigger for either gun and you're ready to weld. No time wasted toggling switches!



Industrial, dual-gear-driven, cast-aluminum drive system features no-tool, quick-change drive rolls and an easy-to-set tension adjustment knob with a scale for consistent settings.

Thermal overload protection shuts down unit if necessary to protect the machine.

Reversible drive rolls with dual grooves allow one set of drive rolls for both .030 and .035 in wire.

Built-in dual gun and cable holder for your MIG gun, spool gun and cables.



Comes Complete With:

- Industrial power cord and plug
- 12 ft (3.7 m), 250 amp M-25 MIG gun for .030/.035 in wire
- Factory-installed dual gas solenoids
- 10 ft (3 m) work cable and clamp
- Argon mix regulator/flow gauge and hose
- Extra contact tips
- Factory-installed running gear/cylinder rack
- .030/.035 in reversible dual groove drive rolls
- Set-up and operation video

Seven taps provides wider welding range of 30–210 amps with improved high and low ends to weld materials from 22 gauge up to 3/8 in (9.5 mm) thick in a single pass.

Easily accessible primary voltage switchover board for quick set up.

12 ft, 250 amp M-25 MIG gun features durable one-piece handle, uncable outer jacket, trigger rated for one million cycles, and steel spring coils protecting cable ends.

TRUE BLUE[®]
3YR. WARRANTY

Welder/generator is warranted for 3 years, parts and labor.
Original main power rectified parts are warranted for 5 years.
Gun warranted for 90 days, parts and labor.

MADE IN **USA**
APPLETON, WI



Miller Electric Mfg. Co.
An Illinois Tool Works Company
1635 West Spencer Street
Appleton, WI 54914 USA

International Headquarters
Phone: 920-735-4505
USA FAX: 920-735-4134
Canadian FAX: 920-735-4169
International FAX: 920-735-4125

Web Site
www.MillerWelds.com



Specifications (Subject to change without notice.)



Rated Output	Amperage Range	Max. Open-Circuit Voltage	Amps Input at Rated Output, 60 Hz				Wire Type and Diameter	Wire Feed Speed	Dimensions	Net Weight
			200 V	230 V	KVA	KW				
160 A at 24.5 VDC, 60% Duty Cycle	30–210 A	34.5	31	27	6.5	5.5	Mild Steel/Stainless Steel: .023–.035 in (0.6–0.9 mm) Flux Cored: .030–.045 in (0.8–1.2 mm)	35–700 IPM (0.9–17.8 m/min)	H: 32 in (813 mm) W: 19 in (483 mm) D: 39 in (991mm)	200 lb (91 kg)

Certified by Canadian Standards Association to both the Canadian and U.S. Standards.

Control Panel

1. Wire Speed Control
2. MIG Gun Connector
3. Voltage Control
4. Power Switch
5. Spool Gun Connector

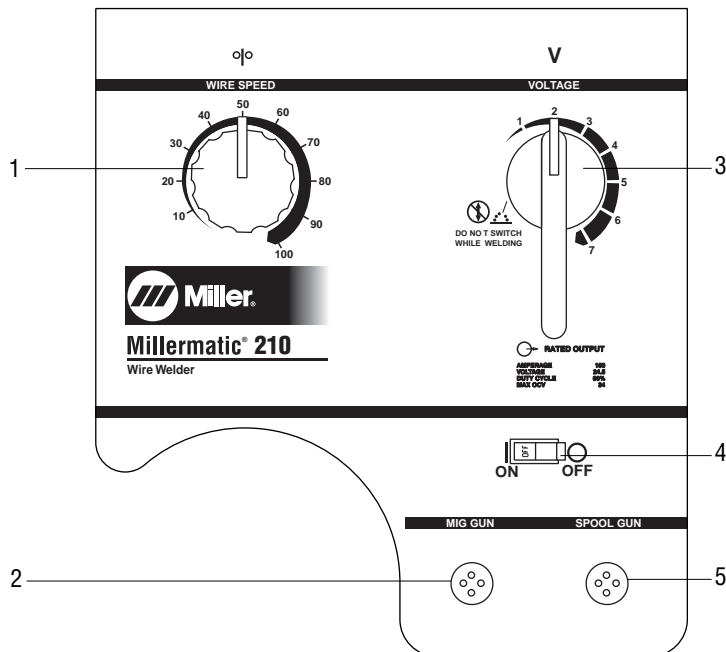

Performance Data

DUTY CYCLE CHART

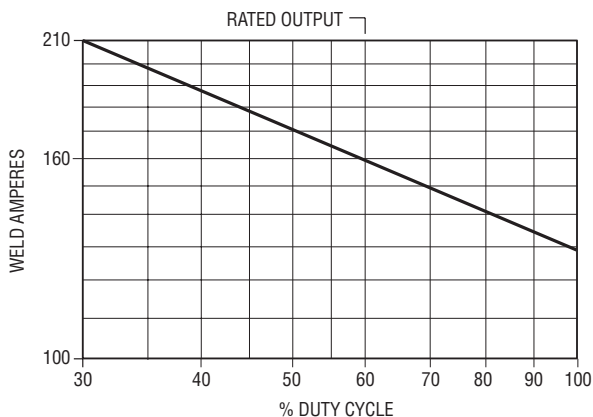

VOLT/AMP CURVES

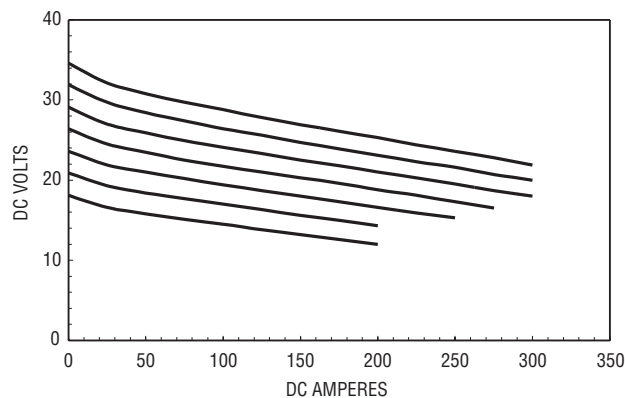

Genuine Miller Accessories

M-25 Replacement Gun

#169 594 10 ft (3 m)

#169 596 12 ft (3.7 m) standard

Gun shipped to run .030–.035 in (0.8–0.9 mm) wire.



Dual Cylinder Rack #042 758

Converts single cylinder rack to a dual rack.



Spoolmate™ 3035 Spool Gun #195 016

Spool gun for aluminum and other wires. 4 in spools; .023 – .035 in (0.6 – 0.9 mm) aluminum, steel and stainless steel. Rated at 150 amps, 60% duty cycle with 20 ft (6 m) cable assembly.



Millermatic®
Protective Cover
with Helmet Bag
#195 142

CO₂ Regulator/Flow Gauge #212 492

Required if using 100% CO₂ gas.

Spoolmate 3035 25 ft Extension Cable Kit #194 996

Extends Spoolmate 3035 an additional 25 ft (7.6 m) from power source.

Consumables (Order from Miller Service Parts.)

For M-25 Gun



Contact Tips

#087 299 .023/.025 in (0.6 mm)

#000 067 .030 in (0.8 mm)

#000 068 .035 in (0.9 mm)

#000 069 .045 in (1.1 mm)

#187 117 .035 in (0.9 mm) heavy-duty tip

#187 118 .045 in (1.2 mm) heavy-duty tip

Tapered Contact Tips

#176 797 .030 in (0.8 mm)

#176 793 .035 in (0.9 mm)

#176 794 .045 in (1.2 mm)



Contact Tip Adapter
#169 728



Replacement Liners

#194 010 .023/.025 in

#194 011 .030–.035 in (standard)

#194 012 .035–.045 in



Nozzles

#200 258 Standard

1/2 in (13 mm) diameter orifice.
Nozzle flush with contact tip.

#169 726

5/8 in (16 mm) diameter orifice.

Nozzle flush with contact tip.

#169 727

5/8 in (16 mm) diameter orifice. Contact tip sticks out of nozzle 1/8 in (3.2 mm).

#169 724

1/2 in (13 mm) diameter orifice. Contact tip recessed 1/8 in (3.2 mm) into nozzle.

#169 725

5/8 in (16 mm) diameter orifice. Contact tip recessed 1/8 in (3.2 mm) into nozzle.

Spot Nozzles

#176 238 Flat

#176 240 Inside corner

#176 242 Outside corner

Tapered Nozzles

Note: Tapered tips are recommended when using a tapered nozzle.

#176 243 3/8 in (9.5 mm) diameter orifice

#178 386 11/32 in (8.7 mm) diameter orifice



Gun Convenience Kit #193 975

Contains:

5 – .035 in (0.9 mm) contact tips (#000 068)

5 – .045 in (1.2 mm) contact tips (#000 069)

2 – Tip adapters (#169 728)

1 – Nozzle adapter (#169 729)

3 – O-rings (#170 468)

2 – Shock washers (#169 730)

1 – 5/8 in (16 mm) diameter orifice nozzle (#169 726)

Drive Rolls

Note: Drive roll kits include two drive rolls and an inlet guide.

V-Grooved Drive Roll Kits (solid wire)

#204 579 .030 & .035 in (0.8 & 0.9 mm) Combination (Reversible)

#087 131 .023/.025 in (0.6 mm)

#079 594 .030 in (0.8 mm)

#079 595 .035 in (0.9 mm)

V-Knurled Drive Roll Kits

(Flux Cored or difficult-to-feed wire)

#079 606 .035 in (0.9 mm)

For Spoolmate™ 3035 Gun



Contact Tips (5 per package)

#199 730 For .023 in (0.6 mm) wire.

#186 419 For .030 in (0.8 mm) wire.

#186 406 For .035 in (0.9 mm) wire.



Nozzle #186 405



Drive Roll (1)

#199 731 For .023 in (0.6 mm) wire.

#186 413 For .030/.035 in (0.8/0.9 mm) wire.



Push Roll (1)

#199 732 For .023 in (0.6 mm) wire.

#186 414 For .030/.035 in (0.8/0.9 mm) wire.

Typical Installations



**MIG (GMAW) or Flux Cored (FCAW)
Basic Equipment**

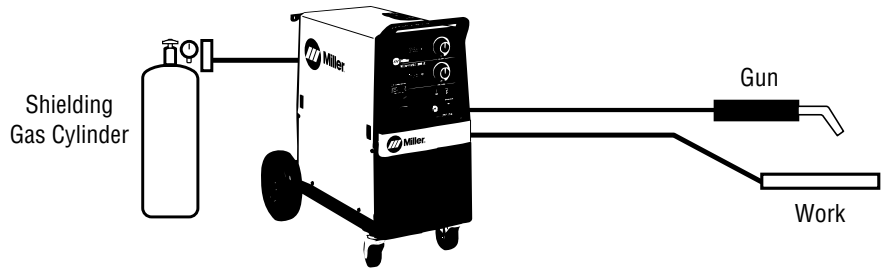

Ordering Information

Equipment and Options	Stock No.	Description	Qty.	Price
Millermatic® 210	#907 046	200(208)/230 V, 60 Hz		
Millermatic® 210 Package	#951 006	200(208)/230 V, 60 Hz with Spoolmate 3035, dual cylinder rack, and Argon mix regulator/flow gauge and hose		
Guns				
M-25 Gun	#169 594	10 ft (3 m), .023–.035 in (0.6–0.9 mm)		
	#169 596	12 ft (3.7 m), .023–.035 in (0.6–0.9 mm)		
Spoolmate™ 3035	#195 016	Spool gun for aluminum		
25 ft Extension Kit	#194 996	For Spoolmate 3035		
Accessories				
Protective Cover with Helmet Bag	#195 142			
CO ₂ Regulator/Flow Gauge	#212 492	Required if using 100% CO ₂ gas		
Electrode Wire				
Dual Cylinder Rack	#042 758	Field installed		
Shielding Gas Cylinder				
Helmet/Gloves/Wire Brush				
Consumables (Order from Miller Service Parts.)				
Contact Tips				
Contact Tip Adapter				
Replacement Liners				
Nozzle				
Spot Nozzles				
Gun Convenience Kit	#193 975			
Drive Rolls				

Date:

Total Quoted Price:



Distributed by: